

ENERGY DISTRIBUTION

Analysis of Power Distribution and DSM: High Voltage Distribution System (HVDS) and Energy Efficient Agriculture Pumpsets (EAPS) in Andhra Pradesh

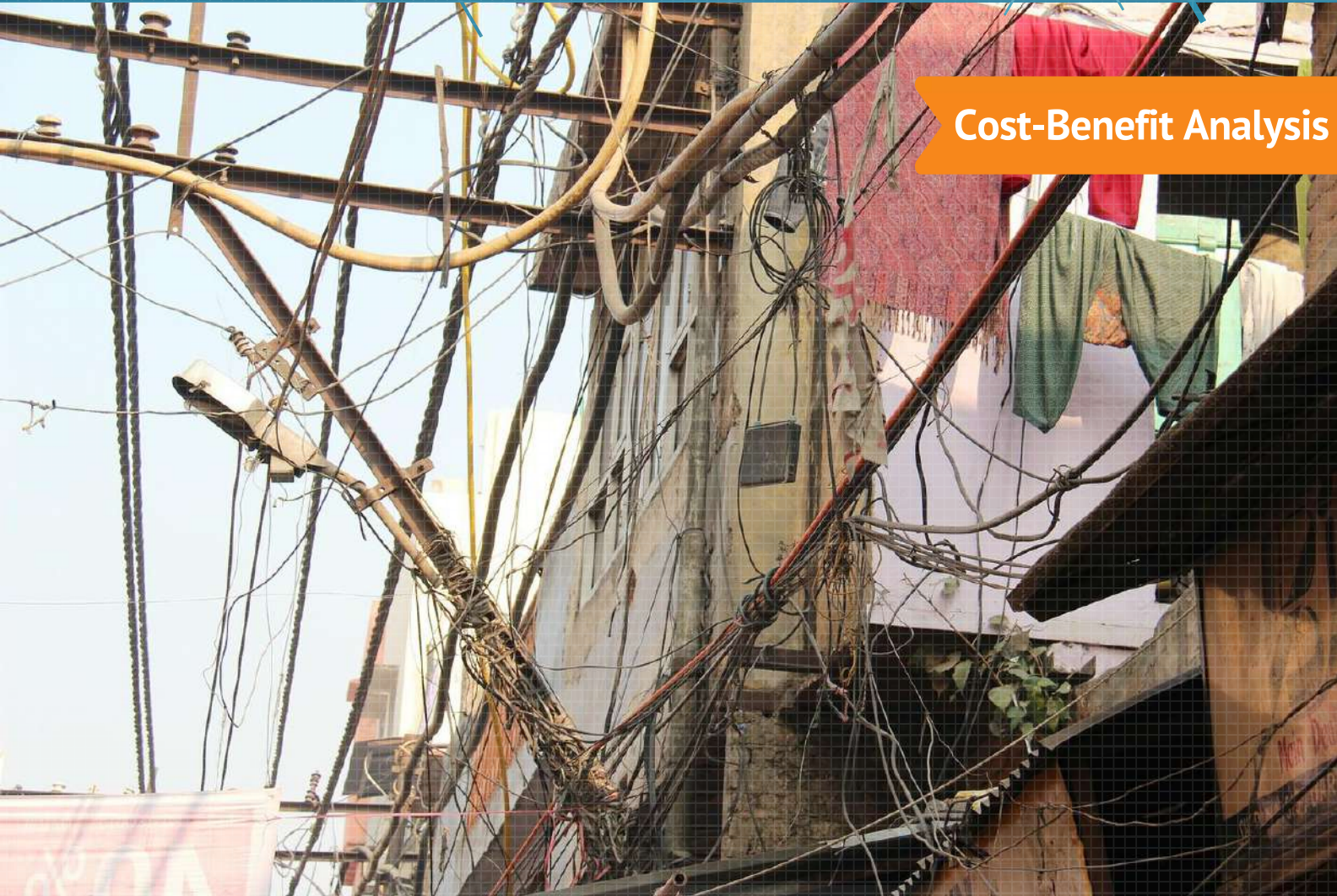

Cost-Benefit Analysis

AUTHORS: **Dr. Gaurav Bhatiani** **Bhawna Tyagi** **Sonali Chowdhry**
COO, IL&FS and Dean, IAAD Senior Officer, IL&FS Officer, IL&FS

© 2018 Copenhagen Consensus Center

info@copenhagenconsensus.com

www.copenhagenconsensus.com

This work has been produced as a part of the Andhra Pradesh Priorities project under the larger, India Consensus project.

This project is undertaken in partnership with Tata Trusts.

TATA TRUSTS

Some rights reserved



This work is available under the Creative Commons Attribution 4.0 International license ([CC BY 4.0](https://creativecommons.org/licenses/by/4.0/)). Under the Creative Commons Attribution license, you are free to copy, distribute, transmit, and adapt this work, including for commercial purposes, under the following conditions:

Attribution

Please cite the work as follows: #AUTHOR NAME#, #PAPER TITLE#, Andhra Pradesh Priorities, Copenhagen Consensus Center, 2017. License: Creative Commons Attribution CC BY 4.0.

Third-party content

Copenhagen Consensus Center does not necessarily own each component of the content contained within the work. If you wish to re-use a component of the work, it is your responsibility to determine whether permission is needed for that re-use and to obtain permission from the copyright owner. Examples of components can include, but are not limited to, tables, figures, or images.

Cost Benefit Analysis of Power Distribution and DSM: High Voltage Distribution System (HVDS) and Energy Efficient Agriculture Pumpsets (EEPS) in Andhra Pradesh

Andhra Pradesh Priorities
An India Consensus Prioritization Project

Dr. Gaurav Bhatiani¹, Bhawna Tyagi², Sonali Chowdhry³

¹COO, IL&FS and Dean, IAAD

²Senior Officer, IL&FS

³Officer, IL&FS



Working draft as of May 18, 2018

IL&FS Academy of Applied Development (IAAD)

| | |
|--|-----------|
| LIST OF FIGURES..... | 4 |
| LIST OF TABLES | 4 |
| LIST OF ABBREVIATIONS | 5 |
| ACADEMIC ABSTRACT | 1 |
| POLICY ABSTRACT | 2 |
| THE PROBLEM | 2 |
| INTERVENTION 1: HIGH VOLTAGE DISTRIBUTION SYSTEM (HVDS) | 4 |
| <i>Overview</i> | 4 |
| <i>Implementation Considerations</i> | 4 |
| <i>Costs and Benefits</i> | 4 |
| Costs..... | 4 |
| Benefits | 5 |
| INTERVENTION 2: ENERGY EFFICIENT AGRICULTURAL PUMPSETS (EEPS) | 5 |
| <i>Overview</i> | 5 |
| <i>Implementation Considerations</i> | 5 |
| <i>Costs and Benefits</i> | 6 |
| Costs..... | 6 |
| Benefits | 6 |
| BCR TABLE..... | 6 |
| 1. INTRODUCTION..... | 8 |
| 1.1 THEORY..... | 13 |
| <i>CBA Methodology</i> | 14 |
| 2. HIGH VOLTAGE DISTRIBUTION SYSTEM (HVDS)..... | 15 |
| 2.1 DESCRIPTION OF INTERVENTION | 15 |
| 2.2 LITERATURE REVIEW | 17 |
| 2.3 DATA..... | 21 |
| 2.3.1 <i>Source of Data</i> | 21 |
| 2.3.2 <i>Assumptions</i> | 21 |
| 2.4 CALCULATION OF COSTS AND BENEFITS | 25 |
| 2.4.1 <i>Estimation of Costs</i> | 25 |
| 2.4.2 <i>Estimation of Benefits</i> | 25 |
| 2.5 ASSESSMENT OF QUALITY OF EVIDENCE..... | 26 |
| 2.6 SENSITIVITY ANALYSIS | 27 |
| 3. HVDS AND ENERGY EFFICIENT AGRICULTURAL PUMPSETS (EEPS) | 28 |
| 3.1 DESCRIPTION OF INTERVENTION | 28 |

| | |
|---|-----------|
| 3.2 LITERATURE REVIEW | 28 |
| 3.3 DATA..... | 31 |
| 3.4 CALCULATION OF COSTS AND BENEFITS | 32 |
| 3.4.1 <i>Estimation of Costs</i> | 32 |
| 3.4.2 <i>Estimation of Benefits</i> | 33 |
| 3.5 SENSITIVITY ANALYSIS | 33 |
| 4. CONCLUSION | 35 |
| 5. REFERENCES..... | 37 |
| 6. ANNEXURE..... | 41 |

List of Figures

| | |
|---|----|
| Figure 1: AT&C Losses Trajectory for APDISCOMs..... | 10 |
| Figure 2: CBA Methodology..... | 15 |
| Figure 3: Electricity Distribution in existing LT network | 16 |
| Figure 4: Electricity Distribution using HVDS network..... | 17 |

List of Tables

| | |
|---|----|
| Table 1: Cost and Benefits of HVDS intervention | 5 |
| Table 2: Cost and Benefits of HVDS and EEPS intervention..... | 6 |
| Table 3: Summary of Benefit, Cost and BCR..... | 7 |
| Table 4: Summary of Findings from different studies focusing on HVDS | 20 |
| Table 5: General Assumptions..... | 23 |
| Table 6: Assumptions related to cost of HVDS Intervention | 24 |
| Table 7: Assumptions related to benefits from HVDS Intervention..... | 24 |
| Table 8: Cost and Benefits of HVDS intervention | 26 |
| Table 9: Variables and range for Sensitivity Analysis..... | 27 |
| Table 10: Results of Sensitivities under HVDS intervention..... | 27 |
| Table 11: Summary of Findings from different studies focusing on EEPS | 31 |
| Table 12: Assumptions related to cost of HVDS and EEPS Intervention..... | 32 |
| Table 13: Assumptions related to benefits from HVDS and EEPS Intervention | 32 |
| Table 14: Cost and Benefits of HVDS and EEPS intervention..... | 33 |
| Table 15: Key risk factors for Sensitivity Analysis | 34 |
| Table 16: Results of Sensitivities under HVDS and EEPS intervention | 34 |
| Table 17: Summary of Benefits, Cost and BCR at three discount rate..... | 36 |
| Table 18 : Case studies of Energy Savings | 41 |

List of Abbreviations

- **A.P.:** Andhra Pradesh
- **Ag-DSM:** Agriculture Demand Side Management
- **APDISCOMs:** Andhra Pradesh Distribution Companies
- **APDRP:** Accelerated Power Development and Reforms Programme
- **APEPDCL:** A.P. Eastern Power Distribution Company Limited
- **APSPDCL:** A.P. Southern Power Distribution Company Limited
- **AT&C:** Aggregate Transmission and Commercial losses
- **BCM:** Billion cubic metres
- **BCR:** Benefit Cost Ratio
- **Bgl:** Below Ground Level
- **CAGR:** Compound Annual Growth Rate
- **CBA:** Cost Benefit Analysis
- **DEFP:** Domestic Efficient Fans Programme
- **DELP:** Domestic Efficient Lighting Programme
- **DISCOMs:** Distribution Companies
- **DSM:** Demand Side Management
- **DTR:** Distribution Transformer
- **EEPS:** Energy Efficient Pumpsets
- **ESCO:** Energy Services Companies
- **GDP:** Gross Domestic Product
- **HP:** Horsepower
- **HV:** High Voltage
- **HVDS:** High Voltage Distribution System
- **LT:** Low Tension
- **MU:** Million Units
- **NPCL:** Noida Power Company Limited
- **NPV:** Net Present Value
- **RGVY:** Rajiv Gandhi Grameen Vidyutikaran Yojna
- **SEB's:** State Electricity Board's
- **T&D:** Transmission and Distribution
- **UDAY:** Ujjwal DISCOM Assurance Yojana

Academic Abstract

Power distribution system has been characterized with high losses in most parts of the country. Aggregate transmission and commercial (AT&C) losses in India were 24 percent in 2015-16 (PFC report, 2017), higher than the established international norms (Kapure and Mahajan, 2016). High losses have resulted in poor financial health of the sector and utilities i.e. State Electricity Board's (SEB's) and Distribution Companies (DISCOMs). The consequence of accumulated losses in the utilities means that the owners i.e. the State Governments have to provide subsidies (in various forms but generally through direct budgetary support) on an ongoing basis. In Andhra Pradesh (A.P.), annual subsidy support varied between INR 3,188 crores in 2014-15 to INR 3,700 crores in 2017-18 (APEREC, 2015; 2017). Among other sectors, agriculture has been one of the major inefficient user of electricity in India. The Government of A.P. has been a leader in power distribution reform and agricultural demand side management. It has initiated various energy efficiency measures such as introduction of High Voltage Distribution System (HVDS), replacement of inefficient pumps with energy efficient pumps (EEPS), and introduction of solar pumpsets, amongst others. Some of the initiatives have reached scale such as HVDS (implemented in 54% of the network) while others such as EEPS are in early stages. In this context, A.P. is poised uniquely compared to most other states. The benefit of these initiatives are already evident to an extent through reduction of inefficient subsidies. Further, they are enabling several indirect benefits in other sectors such as enabling more optimum utilization of ground water resources and increasing spending in social sectors such as education, health and sanitation.

The research paper aims to conduct cost-benefit analysis of interventions targeting power distribution system through two interventions:

- i. High Voltage Distribution System (HVDS): Conversion of low tension lines feeding agriculture consumers to HVDS
- ii. HVDS and Energy Efficient Pumpsets (EEPS): Intervention 1 plus replacement of inefficient pumpsets with efficient ones.

The first intervention focuses on improving power distribution and reducing losses. Second intervention on the other hand focuses on demand side management in the agriculture sector along with improvement in distribution.

Our analysis suggests that up-gradation of the distribution system to HVDS will have net benefit of INR 12,881 crore (at 5 per cent discount rate) with a BCR of 2.80. Second intervention i.e. HVDS combined with EEPS have net benefits of INR 29,130 crore (at 5 per cent discount rate) with a BCR of 3.06. Thus, both interventions were economically viable but higher benefits are observed in the latter case.

Policy Abstract

The Problem

Power distribution is the weakest link in Indian power system due to technical and management inefficiencies in the system. Political interference in tariff setting and operations have further accentuated the state of affairs. Financial losses have resulted in inadequate investments leading to inadequate and poor quality of supply i.e. frequent interruptions and poor voltage level and dissatisfied consumers in most parts of the country (Bansal, Gill and Gupta, 2012). Presently, AT&C losses in India were 24 percent in 2015-16 (PFC, 2017), significantly higher than the established international norms (Kapure and Mahajan, 2016).

Several initiatives have been introduced to reform the sector and reduce AT&C losses along with a policy and regulatory framework such as the Electricity Act 2003, National Electricity Policy 2005, Accelerated Power Development and Reforms Programme (APDRP) and the Ujjwal DISCOM Assurance Yojana (UDAY) scheme. Following the implementation of these initiatives, AT&C losses (average) at the national level have reduced from 38 percent in 2003-04 to 24 percent in year 2015-16 (PFC, 2005; 2017). AT&C losses in A.P. are amongst the lowest as compared to other states. Further, a consistent downward trend is noted from 13.3 per cent in 2014-15 to 12.28 per cent in 2017-18 (as shown in **Figure 1** (page 15)). One of the major reason for significantly lower level of losses is A.P.'s leadership in upgrading the network serving agricultural consumers to HVDS (GoI and GoAP, 2017).

Among other sectors, agriculture is identified as one of the major inefficient user of electricity. In 1960s, rural electrification programme was introduced to enhance agricultural output using groundwater for irrigation. Due to un-metered supply and flat rate electricity tariff provided for irrigation, the number of pumpsets has increased substantially. Further, unregulated and

free water also contributed to over-exploitation of groundwater resources. Subsidized power intended to benefit the farmers resulted in problems such as pilferage, theft, and acted as a cushion for covering increasing transmission and distribution (T&D) losses of the utilities. This resulted in deterioration of the financial health and a significant burden on the state finances. One of the major reasons for high losses was the adoption of low tension distribution network spread over long distances to serve disperse and relatively small individual agriculture connections. This resulted not only in high technical losses (I^2R) but also high commercial losses by enabling easy tapping into the network. Theft of power was further facilitated by unmetered supply and flat tariff.

Deterioration in financial condition resulted in low investments in network planning and up-gradation, thereby adversely affecting farmers due to poor availability (supply mainly during night hours) and quality of power i.e. frequent power cuts, voltage fluctuations consequently resulting in failure of pumpsets. Poor quality of supply increased the maintenance and replacement cost to the farmers due to frequent burnout of pumpsets. As a result, farmers tend to resort to inefficient motors with thicker armature coils to withstand higher current. Further, energy intensity of pumping increased due to falling groundwater tables from overexploitation caused by “always on” mitigating strategy adopted by the farmers in response to poor availability. This causes reduced on-farm productivity and lowered farm profits (Ag-DSM, 2011). It is a vicious cycle in which all stakeholder i.e. farmers, DISCOMs, and the State Government face ever increasing losses.

In A.P., there are two DISCOMs i.e. A.P. Eastern Power Distribution Company Limited (APEPDCL) serving approximately 2.6 lakh agricultural consumers with AT&C loss level of 13.95 per cent and A.P. Southern Power Distribution Company Limited (APSPDCL) serving approximately 12 lakh agricultural consumers with AT&C loss level of 10.02 per cent. Agriculture is one of the major consumer of electricity with a share of 24 per cent in total sales. However, the contribution of the sector in revenue was only 0.47 per cent in 2015-16 (APER, 2016). To reduce the AT&C losses and improve the performance of utility sector, A.P. had started conversion of existing LT network to HVDS as early as 2006. Till 2017, network serving 8.97 lakh agricultural consumers out of 14.64 lakh was already covered under this system (APSPDCL, 2017; APEPDCL, 2017; CEA, 2015).

Further, the Ministry of Power along with Bureau of Energy Efficiency and Energy Efficiency Services Ltd has initiated pilots for improving agriculture pump efficiency in East Godavari district of Andhra Pradesh by replacing 2496 inefficient pumps with EEPS (EESL, 2014). This research paper aims to conduct cost-benefit analysis of interventions targeting energy efficiency in power distribution, namely HVDS and EEPS. The paper analyzes both direct and indirect cost and benefits associated with the interventions to facilitate policymaker in prioritizing the investments.

Intervention 1: High Voltage Distribution System (HVDS)

Overview

The HVDS intervention aims to upgrade LT agricultural network to HVDS by replacing existing transformers (mostly 100/63 kVA) with smaller capacity 3-phase distribution transformers (16/25 kVA) close to the consumer load points (APEPDCL, 2016; USAID, 2010). Implementation rate of HVDS will improve voltage profile, reduce LT Line losses, and lower the failure of distribution transformer and pumpset burn-out. This intervention is proposed to be implemented by the respective DISCOMs in network serving agricultural consumers.

Implementation Considerations

In A.P., network serving 8.97 lakh agricultural consumers was already covered under this system (APSPDCL, 2017; APEPDCL, 2017). All the remaining 7.67 lakh LT agricultural network are proposed to be converted into HVDS as a part of this intervention. The life of the project has been assumed to be 25 years. As the capex investment required for the project is high, raising finance is one of the crucial risk factors. The success of HVDS is measured in terms of reduction in AT&C losses. Majority of data for the research was sourced from published reports. However, we found limited evidence for variables such as DTR failure rate, pumpset failure rate, etc. Thus, the quality of evidence was strong for most parameters but moderate for some of them.

Costs and Benefits

Costs

The total cost of HVDS include capex cost of conversion of LT lines into HV (11 kV) lines and erection of HVDS transformer (16 kVA). Total investment at 5 per cent discount rate was estimated to be INR 7,147 crore (**Table 1**).

Benefits

There are four types of benefits emanating from HVDS intervention: energy savings due to lower losses, savings due to reduction in pumpset failure, savings due to reduction in DTR failure rate and carbon savings. Total benefit at 5 per cent discount rate was estimated to be INR 20,028 crore (Table 1).

Table 1: Cost and Benefits of HVDS intervention

| Costs | INR Crore | Benefits | INR Crore |
|-------------------|--------------|---|---------------|
| Capex | 7,147 | Value of Energy Savings | 232 |
| | | Value of Carbon Saving | 45 |
| | | Savings (Reduction in pumpset failure) | 18,944 |
| | | Savings (Reduction in DTR failure rate) | 807 |
| Total Cost | 7,147 | Total Benefit | 20,028 |

Source: Author's Calculation; Notes: All figures assume a 5% discount rate

Thus, the BCR in HVDS intervention was 2.80 at 5 per cent discount rate.

Intervention 2: Energy Efficient Agricultural Pumpsets (EEPS)

Overview

The second intervention proposes to replace inefficient pumpsets with high energy efficient pumpsets. HVDS is a pre-condition to implement EEPS in order to ensure that pumps deliver the expected savings. Old inefficient pumps will be destroyed to ensure that they are not reused through grey market sales.

Implementation Considerations

This intervention may be implemented by the Bureau of Energy Efficiency (BEE) or Energy Efficiency Services Ltd (EESL) in collaboration with respective DISCOMs. Alternatively, private Energy Services Companies (ESCO) may be enlisted for the job. There were 15.7 lakh pumpsets in 2015. The number of pumpsets has been appropriately adjusted and included in the analysis. All pumpsets were proposed to be replaced in 2018 and the life of the project is assumed to be 25 years. The major risk to implementation may be the reluctance of the farmers to shift to EEPS and install meters. The success of EEPS will be measured in terms of energy savings. The

quality of evidence was “Moderate to Strong” as data on most parameters was robust but limited evidence existed for a few.

Costs and Benefits

Costs

The total cost of energy efficient pumpsets has two components. First, cost of energy efficient pumpset which includes installation cost. Second, cost of metering and related accessories. Total investment at 5 per cent discount rate was estimated to be INR 14,164 crore.

Benefits

There are four benefits of EEPS intervention: energy savings due to lower consumption by EEPS and lower losses, savings due to reduction in pumpset failure, savings due to reduction in DTR failure rate and Carbon savings. Energy and carbon savings are higher in this case as new pumpsets require 30 per cent less energy. Total benefit at 5 per cent discount rate was estimated to be INR 43,294 crore.

Table 2: Cost and Benefits of HVDS and EEPS intervention

| Costs | INR Crore | Benefits | INR Crore |
|-------------------|---------------|---|---------------|
| Capex | 14,164 | Value of Energy Savings | 17,819 |
| | | Value of Carbon Saving | 5,724 |
| | | Savings (Reduction in pumpset failure) | 18,944 |
| | | Savings (Reduction in DTR failure rate) | 807 |
| Total Cost | 14,164 | Total Benefit | 43,294 |

Source: Author’s Calculation; Notes: All figures assume a 5% discount rate

Thus, the BCR in EEPS intervention was 3.06 at 5 per cent discount rate.

BCR Table

The BCR for HVDS intervention at 5 per cent discount rate is 2.80 and for second intervention is 3.06 (**Table 3**). Therefore, we can conclude that both interventions are economically viable but the BCR was higher in the latter case.

Table 3: Summary of Benefit, Cost and BCR

| Interventions | Benefit (INR Crore) | Cost (INR Crore) | BCR | Quality of Evidence |
|---------------|---------------------|------------------|------|---------------------|
| HVDS | ₹ 20,028 | ₹ 7,147 | 2.80 | Strong/Moderate |
| HVDS and EEPS | ₹ 43,294 | ₹ 14,164 | 3.06 | Strong/Moderate |

Source: Author's calculation; Notes: All figures assume a 5% discount rate

1. Introduction

Power distribution in India has one of the largest consumer base in the world catering to nearly 236 million consumers with a connected load of about 561 GW (CEA, 2015). It comprises of around 73 distribution utilities, 13 electricity departments, 17 private DISCOMs, 41 corporatized DISCOMs and 2 SEB's (Indian Power Sector report, 2013). The aggregate transmission and commercial (AT&C) losses in India were 24 per cent, significantly higher than the established international norms (PFC report, 2017). High losses have resulted in poor financial health of SEB's and DISCOMs thereby restricting investments in up-gradation of the network. Thus, power supply was characterized by low-quality in form of unscheduled cuts, load shedding, fluctuating voltage and erratic frequency. Further, low voltage levels lead to higher technical losses and frequent burnout of machinery and equipment. Other challenges include unsustainable and market-distorting cross subsidies; non-payment of bills; villages without access to energy services; and an incentive-distorting tariff system that cannot cover costs (Indian Power Sector report, 2013).

A highly inefficient tariff structure which discriminates across consumers through a complex cross subsidization has created perverse incentives for all stakeholders. Flat tariff and unmetered supply provided through LT network created and enabled high losses with very low accountability for utility engineers and managers. Industrial and commercial units face high tariffs while private households and agricultural users pay less. As a result, industrial and commercial units tend to switch to captive power, which is also more reliable but often costlier than grid power, leading to decreased competitiveness. On the other hand, farmers, who often get power at zero marginal cost, use highly energy-inefficient pumpsets for irrigation.

Overtime, several initiatives were introduced to reduce AT&C losses along with changes in the regulatory framework. Some of the important policies and regulations include the Electricity Act 2003, National Electricity Policy 2005 and National Tariff Policy 2006 with an aim to enhance efficiency and improve the services. The Government has also made significant investments in the distribution sector through the RGGVY, APDRP and UDAY schemes. The aim of these programs was to provide access of electricity to all, reduce the AT&C losses to around 15 percent, and additionally feeder separation, improvement of sub-transmission and distribution network, and metering to reduce losses. Following the implementation of these

initiatives, AT&C losses (average) at the national level have reduced from 38 percent in 2003-04 to 24 percent in year 2015-16 (PFC, 2005; 2017). State Governments had also initiated similar schemes to reduce the losses and improve performance of the utilities. In Gujarat, for example, the State Government made efforts to bring down inefficiencies through various efforts such as feeder bifurcation, introducing HVDS in select locations, improving customer services, among others (Alam et al., 2014). These efforts resulted in reduction in AT&C losses from 35.2 per cent in 2004-05 to 12.4 per cent in 2015-16 (Gandhi, 2017). In Delhi, AT&C losses were as high as 53 per cent in 2001, mainly due to theft. To reduce the losses, the Government created a public private partnership and two private companies were selected through a competitive process, which enabled loss reduction to 18.5 per cent in 2008 (Alam et al., 2014) and 8.74 per cent for Tata Power Delhi Distribution (TPDDL) by 2015-16 (DERC, 2017).

To reduce the AT&C losses, Government of A.P. started conversion of network serving agricultural consumers to HVDS in 2006 and 54 per cent agricultural network has already been upgraded to HVDS (APSPDCL, 2017; APEPDCL, 2017; CEA, 2015). As a result, AT&C losses in A.P. are amongst the lowest as compared to other states. They have consistently demonstrated a steady downward trend from 13.3 per cent in 2014-15 to 12.28 per cent in 2017-18 as shown in **Figure 1** (Gol and GoAP, 2017). Despite lower AT&C losses, accumulated financial losses of the DISCOMs have been increasing and were INR 14,484 crore in 2015-16. Further, subsidy provided by the State Government has increased over the years to INR 3,700 crores in 2017-18 (APEREC, 2018). This is due to a variety of reasons including inability of DISCOMs to make a case for tariff increase, high power procurement cost and less than optimal operational performance. .

Figure 1: AT&C Losses Trajectory for APDISCOMs

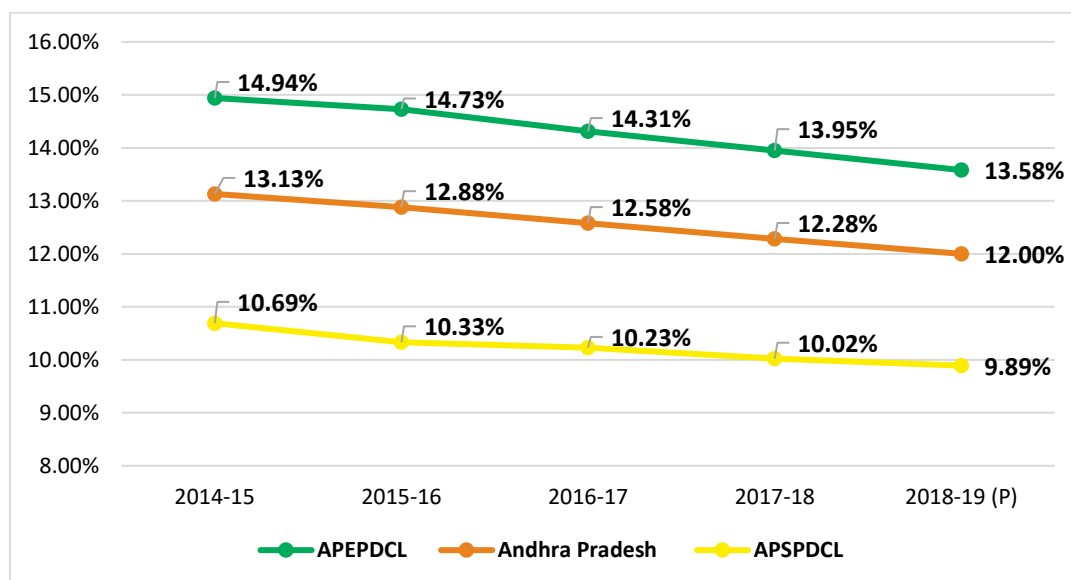

Source: Gol and GoAP, 2017

Among other sectors, agriculture is identified as one of the major inefficient user of electricity. Despite its declining share in gross domestic product (GDP), agriculture remains an integral part of the economy by contributing significantly towards employment, livelihood and food security. The growth rate of agriculture sector has been fluctuating from 1.5 per cent in 2012-13 to 5.6 per cent in 2013-14, (-) 0.2 per cent in 2014-15, 0.7 per cent in 2015-16 and 4.9 per cent in 2016-17 (Economic Survey, 2018). This is partly explained by the fact that more than 50 percent of agriculture in India is rainfall dependent resulting in high crop failure rate due to drought and floods.

By the end of the 1970s, groundwater had become the main source of irrigation in many parts of the country, as it enabled reduction of crop failure. This was facilitated by subsidies provided under rural electrification programme introduced in 1960s to enhance agricultural productivity through development of local irrigation infrastructure. Due to un-metered supply and flat rate, the number of pumpsets increased substantially in a short period of time. There were more than 20 million energized irrigation pumpsets (IP) in the country extracting more than 90% of the country's groundwater and consuming 23% of its total electricity (Ag-DSM, 2011).

Presently, about a fifth of electricity use is for irrigation (including a significant proportion of wasted energy due to pump inefficiency and other losses) and by 2050 water demand for

irrigation is expected to increase by 130 per cent (Grönwall, 2014). Further, largely unregulated access to water have also contributed significantly to over-exploitation of groundwater. Even though groundwater irrigation has enabled self-sufficiency in terms of food production, but it has adversely affected the water table in many parts of the country. Evidence suggests that Indian farmers respond to electricity subsidies by expanding the area cultivated, particularly for water-intensive crops such as rice and sugarcane especially due to minimum support price offered for some of the crops (Ag-DSM, 2011).

Subsidized power intended to benefit the farmers resulted in problems such as pilferage, theft, and acted as a cushion for covering increasing transmission and distribution (T&D) losses of the utilities. This resulted in deterioration of the financial health and a significant burden on the state finances. One of the major reasons for high losses is the low tension distribution network spread over long distances to serve dispersed and relatively small individual agriculture connections. This results not only in high technical losses (I^2R) but also high commercial losses by enabling easy tapping into the network. Theft of power was further facilitated by unmetered supply and flat tariff structure. This in turn has affected the viability of the generation companies upstream and is a major source of state fiscal deficits. In Andhra Pradesh, for example, annual subsidy support varied between INR 3,188 crores in 2014-15 to INR 3,700 crores in 2017-18 (APEREC, 2015; 2017). Poor financial health of DISCOMs results in low investments in network up-gradation and planning, adversely affecting farmers due to poor availability and quality of power supply and frequent power cuts. (Ag-DSM, 2011)

A direct impact of poor quality of power is to increase the maintenance and replacement cost of pumpsets. As a result, farmers tend to select robust motors with thicker armature coil windings to withstand large currents. However, these motors are significantly less efficient, often consuming 30 per cent to 50 per cent more electricity as compared to an EEPS. Further, due to unreliable power supply, farmers tend to keep the pump always in an “on mode” i.e. the pump draws water when power is available, rather than when water is needed. This leads to over extraction of groundwater, lower water table, forcing farmers to deploy higher capacity pumps to lift water from ever deeper levels. This causes reduced on-farm productivity and lowers farm profits in the long run (Ag-DSM, 2011). It is a vicious cycle in which all stakeholder i.e. farmers, DISCOMs, and the State Government face ever increasing losses.

Several energy efficiency initiatives related to agriculture have been attempted in states such as Gujarat, Tamil Nadu, Andhra Pradesh, Maharashtra and Punjab. In case of Gujarat, in 1997-98, existing pumps were replaced by a mono-block pump of lower capacity, but providing at least equivalent discharge. This resulted in energy saving of 24 per cent to 69 per cent (International Energy Initiative and Prayas, 2010). In case of Tamil Nadu, energy savings due to rectification of suction and delivery pipes alone was from 8 per cent to 14 per cent out of overall energy savings of 19 per cent (International Energy Initiative and Prayas, 2010). Recently, under the guidance of BEE and EESL, Ag-DSM pilot projects were proposed by DISCOMs in eight agriculture intensive states namely Maharashtra, Haryana, Punjab, Rajasthan, Gujarat, Andhra Pradesh, Madhya Pradesh and Karnataka. Four of these pilot programs have already been implemented in the states of Maharashtra, Andhra Pradesh and Karnataka, resulting in energy savings of 25 per cent, 28 per cent and 37 per cent respectively. Various state governments as well as their regulatory authorities are considering initiatives to promote Ag-DSM in their respective states (FICCI, 2017).

In 2015-16, sale of electricity to farmers was around 11 GWh with revenue of INR 314 crore (PFC, 2017). Agriculture is one of the major consumer of electricity with a share of 24 per cent in total sales. However, the contribution of the sector in revenue was only 0.47 per cent in 2015-16 (APEREC, 2016). The requirement of electricity, i.e. both energy and peak demand are expected to increase significantly in Andhra Pradesh from the present level of 43,684 Million Units (MU) to 82,392 MU by 2018-19 (Gol and GoAP, 2017).

In order to reduce the AT&C losses further and enhance demand side management (DSM), APDISCOMs have initiated various energy efficiency initiatives which are under implementation or proposal stage by APSPDCL and APEPDCL. For residential consumers, DSM schemes include DELP, DEFP, and Energy Efficient Tube light Programme. For agricultural consumer, initiatives include replacement of inefficient pumps with EEPS, implementation of HVDS and distribution of solar pumpsets (APSPDCL, 2017; AEPDCL, 2017). A.P. had also started conversion of existing LT network to HVDS as early as 2006. Till 2017, network serving 8.97 lakh agricultural consumers out of 14.64 lakh was already covered under this system (APSPDCL, 2017; APEPDCL, 2017; CEA, 2015). As a consequence, APDISCOMS have realized significant benefit and their loss levels are amongst the lowest in the country.

This research paper aims to conduct cost-benefit analysis of interventions targeting improvement in power distribution namely HVDS and EEPS. In HVDS, LT agricultural network will be upgraded to HVDS lines and will replace existing 100/63 kVA transformers with large number of smaller capacity 3-phase distribution transformers (16/25 kVA) installed closer to the consumer load points which feed to all the consumers through 3 phase 4 wire LT network. In the second intervention, inefficient agricultural pumpsets will be replaced with highly efficient (5 star rated) EEPS of 5 HP capacity on an average. LT agricultural network will be upgraded to HVDS in this intervention as it is a pre-condition for implementing EEPS to ensure that the pumpsets deliver expected savings on a sustained basis and also to incentivize farmers to replace their pumps. The paper analyzes both direct and indirect cost and benefits associated with these interventions to facilitate policymaker in investment decision. The next section discusses the approach and methodology adopted by the study.

1.1 Theory

To evaluate the potential socio-economic impact of different interventions, study has adopted Cost Benefit Analysis (CBA) approach. This approach is widely used to evaluate and compare various programs in policy discussions around the world. In this approach, incremental benefits are compared with the cost of the investment to determine if the benefits exceed the costs. BCR is measured as ratio of discounted present value of interventions benefits to the discounted present value of interventions costs expressed as:

$$BCR = \frac{\sum_{i=1}^n \frac{(B_i)}{(1+r)^i}}{\sum_{i=1}^n \frac{(C_i)}{(1+r)^i}}$$

Here, B, C, r and t denote benefit, cost, discount rate and time frame of the project (t = 1,..., n), respectively. The discount rate was used to calculate net present value for costs and benefits.

A BCR greater than 1 indicates that benefits exceeds the cost of investment i.e. the program generates net benefits and a BCR less than 1 implies the costs of undertaking the program exceed the benefits generated by it. BCRs enable policymakers to compare and rank alternative policy interventions to prioritize among potential intervention strategies.

CBA Methodology

The present study captures both direct and indirect cost and benefits accruing due to implementation of the two interventions. On the benefit side, there are direct benefits which include revenue benefits and energy savings. Apart from direct benefits, research captures the diverse range of indirect benefits such as avoided cost of carbon due to less generation, cost saving due to reduction in pumpset failure rate and reduction in DTR failure rate. Similarly on the cost side, in addition to the capex and opex, the study also considers social and environmental cost.

For the base case scenario, the discount rate of 5percent was used. Any project is subject to various types of risks during life cycle of the project. The study has identified two types of key risk factors: first, cost variables and second, variables with maximum uncertainty. Sensitivity is performed on cost variables as study has kept all the prices constant. However, if there is an escalation in the prices it could affect the BCR. Similarly, there are some variables with uncertainty such as frequency of pumpset failure, energy savings due to EEPS, among other. These values have been sourced from case studies and variation in these values could also affect BCR. As a result, sensitivity analysis was performed on these two type of key risk factors to study the impact on BCR. The methodology of CBA is discussed in **Figure 2**. The key assumptions along with the data sources for the study are explained for each interventions in **section 2.3.1** and **3.3.1**.

Figure 2: CBA Methodology

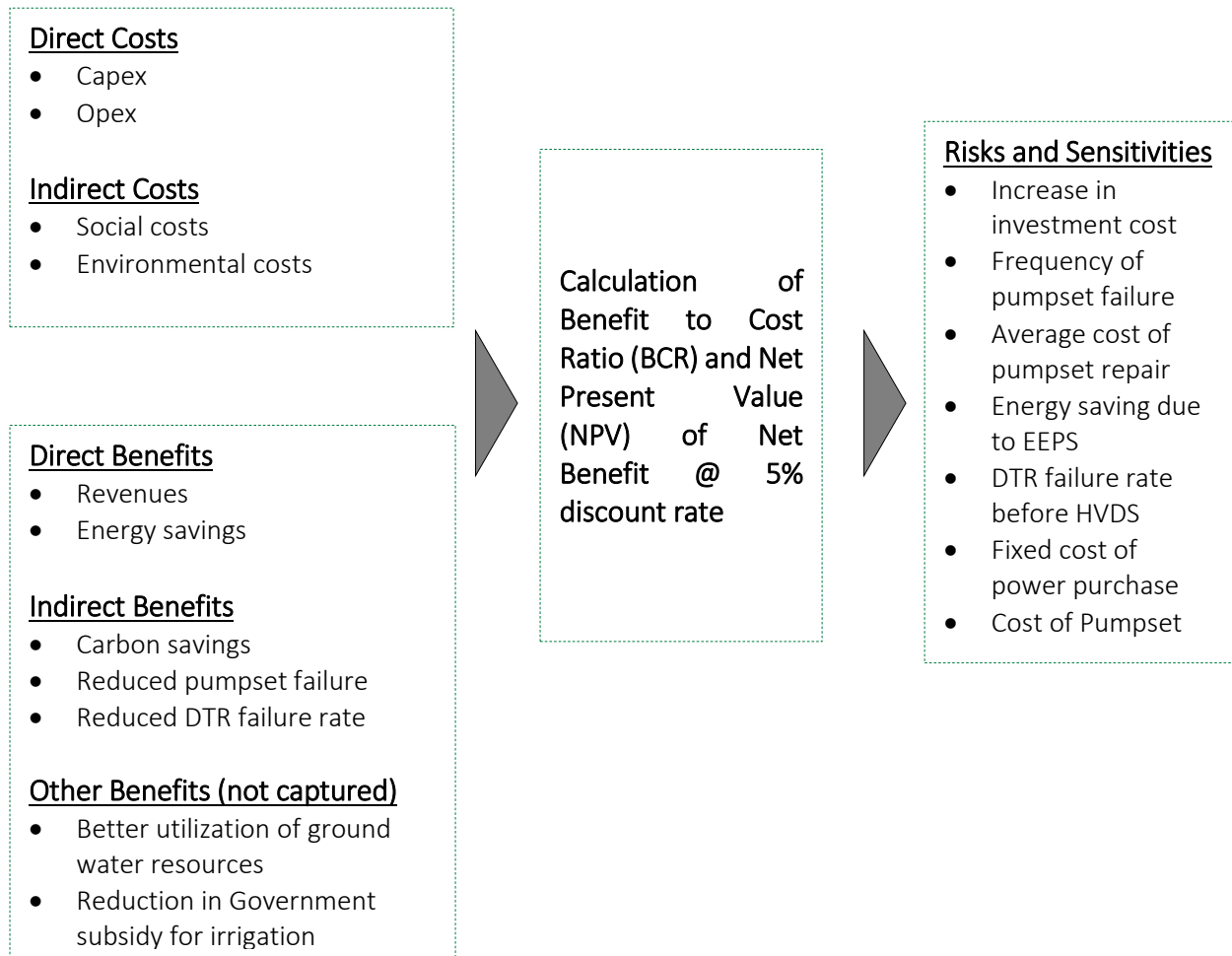

2. High Voltage Distribution System (HVDS)

2.1 Description of intervention

A typical grid transmits power from generating stations through High Voltage (HV) transmission circuits (400/220/132 KV) and substations. The transmission network interfaces with the distribution network at the 132/33kV level. Electricity is then delivered to the load centres (cities) through distribution network comprising of 33/11/0.4 kV lines. At these load points, a distribution transformer (DTR) reduces the voltage from 11kV to 415V to provide the last-mile connection to individual customers, either at 240V (as single-phase supply) or at 415V (as three-phase supply) as shown in **Figure 3**. (APEPDCL, 2016)

Figure 3: Electricity Distribution in existing LT network

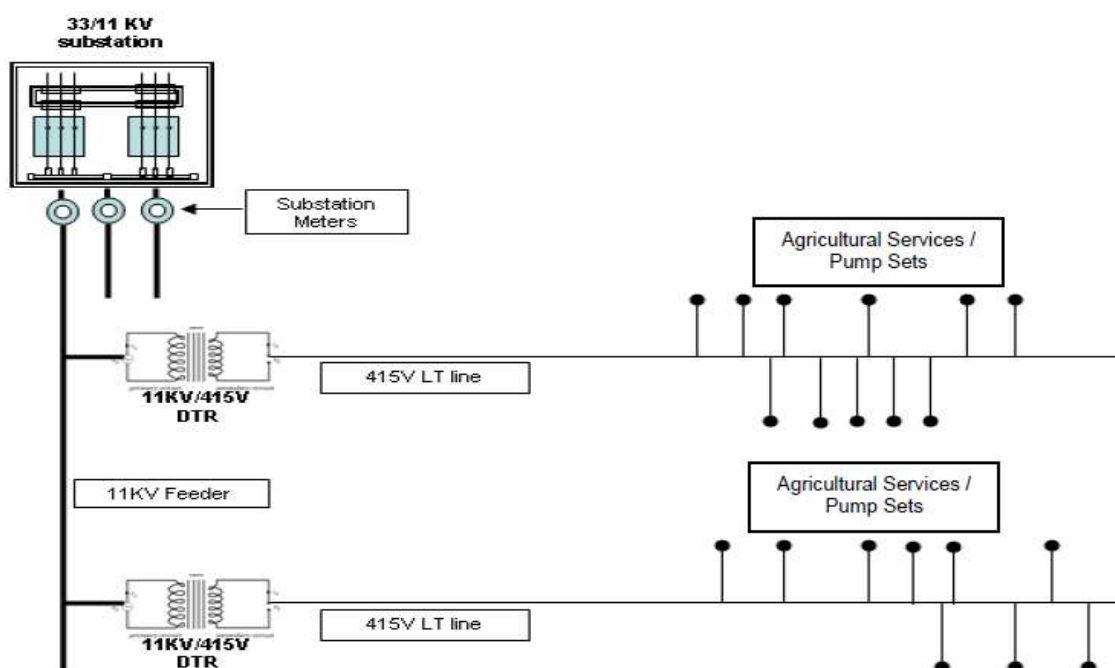

Source: APEPDCL, 2016

To optimize investment in the distribution infrastructure, large capacity DTRs, usually of 100kVA or 63kVA capacity were typically used to serve a large number of consumers from a single DTR. This system is beneficial in settings with high concentration of consumers which require LT lines to cover short distances. However, in rural areas, the consumer density is low as they are dispersed over relatively larger geographical area. As a result, lengthy LT lines were required, resulting in significant line losses and voltage fluctuations. Farmer's often need to resort to larger capacity motors because of low voltage and lowering of ground water tables resulting in overloading of the lines. Further, lengthy LT lines enable theft of electricity and unauthorized connections, thereby overloading the DTR and leading to its frequent failure. As the DTR served a large number of customers, there was little incentive for any one farmer to prevent such overloading. Apart from increasing operation and maintenance expenses, delay in repair or replacement of failed distribution transformer often resulted in damage to the standing crops. Further, voltage fluctuations also contributed to frequent burnouts of pumpsets connected and consequent expenditure on repairs. (APEPDCL, 2016; USAID, 2010)

One well accepted measure to minimize line losses and reduce failure of DTR as well as pumpsets is implementation of high voltage distribution system. HVDS intervention reconfigures the existing Low voltage (LT) network into high voltage distribution system. Long agriculture LT lines are converted into 11 kV lines installing the appropriate capacity distribution transformer near the load shown in the **Figure 4**. (APEPDCL, 2016; USAID, 2010)

Figure 4: Electricity Distribution using HVDS network

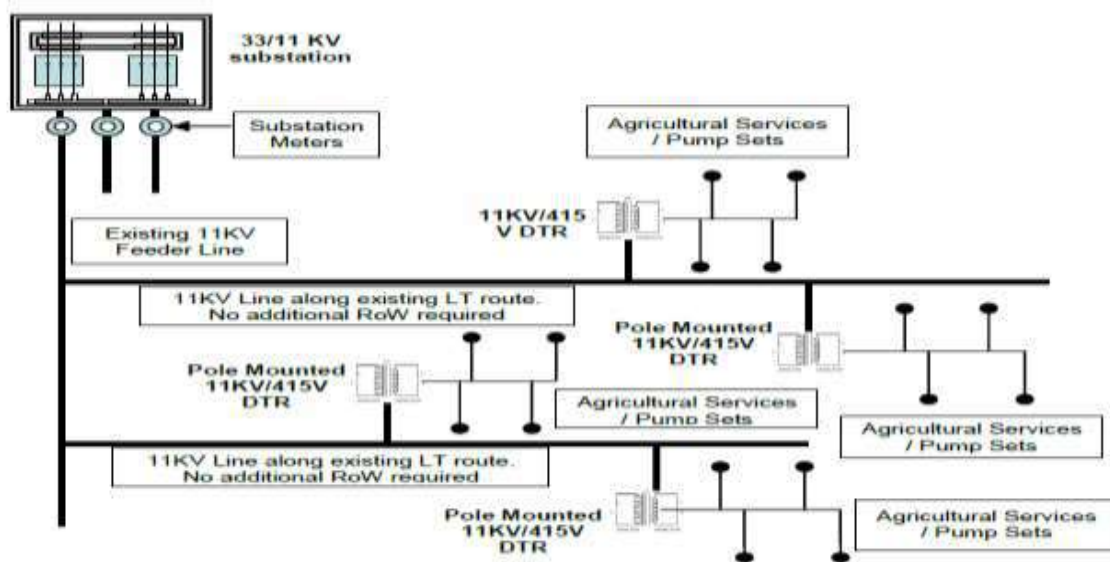

Source: APEPDCL, 2016

HVDS system offers several advantages such as;

- (i) Reduction in technical losses in the system;
- (ii) Reduction in commercial losses.
- (iii) Enhanced reliability and quality of power;
- (iv) Lower burnout of pumpsets due to reduced voltage fluctuations;
- (v) Reduction in DTR failure rate due to elimination of overloading; and
- (vi) Enhanced customer satisfaction

2.2 Literature Review

Power distribution system in India is characterized with AT&C losses significantly higher than the international norm of 15 per cent (Kapure and Mahajan, 2016). Loss percentage are particularly high at secondary distribution i.e. lower voltages such as at 440 V and 220 V. In rural areas, agriculture consumers are dispersed over large geographical areas. Traditionally,

lengthy LT lines were used to serve agricultural customers resulting in significant line losses and voltage fluctuations. Up-gradation of exiting LT network to HVDS system is preferred means of reducing losses as it helps in reducing both technical and commercial losses, reducing transformer failure rate, lowering commercial losses and reduces in pumpset failure rate.

There are several studies which have evaluated the impact of HVDS intervention in India. Jahnvi (2014) studied the impact of HVDS intervention on distribution system of Gundraju Kuppam Substation II Feeder using MATLAB model for simulation. The feeder supplied to 22 agricultural consumer using 100 kVA transformers. The analysis depicts that investment cost for the HVDS intervention was INR 6.4 lakh while the annual savings were INR 2.5 lakh. The payback period for this intervention was 2 years 6 months. The intervention resulted in reduction of both technical and non-technical losses, DTR failure rate, pumpsets burn out and improved tail end voltage. Sharma and Mittal (2016) evaluated the feasibility of two interventions (capacitor placement and HVDS) in 11kV Deetyakhedi Feeder in Rajasthan and calculated the annual saving and payback period from the proposed work. They observed 2.5 percent reduction in losses due to capacitor placement and overall losses declined from 40 per cent to 17 per cent after implementation of HVDS. The analysis suggested the HVDS investment cost was INR 4.45 lakh and the annual savings were INR 2.9 lakh. The payback period for the intervention was 1 year 6 months.

Gupta, Gill and Bansal (2012) discussed the case of 11 kV feeder in Jammu and Kashmir. They estimated the capital outlay for HVDS to be INR 1.95 crore, annual savings of INR 0.86 crore with payback period of 2 years 3 months. In another study, they discuss the case of BHELLA feeder in Punjab (Bansal, Gill and Gupta, 2012). They estimated that capital outlay for HVDS to be INR 2.25 lakh, annual savings of INR 0.75 lakh with payback period of 3 years. Agriculture feeders in Punjab were also studied by Dembra and Sharma (2014 b). They estimated that the line losses declined from 13.8 per cent to 5.4 per cent and tail end voltage increased from 407V to 414V.

In another study, Dembra and Sharma (2014 a) evaluated the case of agriculture feeder in Madhya Pradesh. They estimated that with conversion to HVDS total energy losses per annum declined from 12123 kWh to 8052 kWh due to reduction of power (copper, iron and transformer) losses. Babu, Basani and B (2012) studied the case of Hyderabad South Zone.

They estimated that post-implementation of HVDS, technical losses decline from 15.1 per cent to 10.3 per cent and non-technical losses. The efficiency of the system increased from 84 per cent to 89 per cent and annual loss of revenue declined from INR 1.16 crore to INR 0.36 crore.

Majority of above mentioned studies discussed above have considered energy savings due to decline in technical and non-technical losses. They have not quantified all the benefits accruing from HVDS system such as decline in transformer failure rate, decline in pumpsets failure rate, carbon savings etc. A study by USAID (2010) considered both energy savings and cost savings due to decline in transformer failure rate. They studied the case of four feeders (Kottur - SS1, Murakambattu - SS2, Patnam –SS2, Bangarupalem-SS4) in Andhra Pradesh which were selected to convert LT network to HVDS. There has been significant reduction in line losses, from 18.6 per cent to 5.5 per cent in Kottur, 13.8 per cent to 5.4 per cent in Murakambattu, and 16.8 per cent to 5.3 per cent. In Bangarupalem, line losses reduced from 16.3 per cent to 3.8 per cent following implementation of extended version of HVDS with reinforcement of conductors and installation of rated capacitors. There has also been increase in tail end voltage improved (350V to 420V in Kottur - SS1 and 385V to 430V in Murakambattu - SS2) and reduction in distribution transformer (DTR) failure rate from 15 per cent to 2 per cent. Study by Reddy, Rao and Kumar (2016) have also considered the case of carbon savings in their analysis. They analyzed the impact of HVDS intervention in Karampudi SS, Vepakampally Feeder supplying to 45 agricultural consumers using 100kVA Distribution Transformer. They have used MATLAB model for simulation and estimated that the cost of investment was INR 1.76 crore and annual saving of INR 1.56 crore, with payback period of 1.13 years. They estimated carbon saving worth INR 60 lakhs over a period of 5 years arising from lower energy consumption. Detailed summary of findings from different studies focusing on HVDS are discussed in **Table 4**.

Table 4: Summary of Findings from different studies focusing on HVDS

| Author | Title | Study Areas | Findings |
|-------------------------------|--|---|--|
| USAID (2010) | Best Practices in Technical Loss Reduction –Case Studies | Kottur - SS1, Murakambattu - SS2, Patnam –SS2, Bangarupalem-SS4 | <ul style="list-style-type: none"> • Reduction in line losses in all feeders • Reduction in DTR failure rate from 15 % to 2 % • Increase in Tail end Voltage |
| Jahnavi (2014) | Reduction of Losses in Distribution System Using HVDS with Real Time Application | Gundraju Kuppam SSII | <ul style="list-style-type: none"> • Reduction in both technical and non-technical losses. • Annual Saving : INR 2.5 lakh; Capital Cost: INR 6.4 lakh; Payback period: 2 year 6 months |
| Sharma and Mittal (2016) | Techno-Economic Analysis for Electrical Energy Saving in Distribution Sector through Capacitor Placement and LT Less Distribution System | Deetyakhedi Feeder | <ul style="list-style-type: none"> • Reduction in losses due to capacitor placement is 2.5 %. • Total losses declined from 40 % to 17 % after HVDS • Annual Saving : INR 2.9 lakh; Capital Cost: INR 4.45 lakh; Payback period: 1 year 6 months |
| Reddy, Rao and Kumar (2016) | Comparative Study on Loss & Cost Minimization by Using High Voltage Distribution System | Karampudi SS,Vepakampally | <ul style="list-style-type: none"> • Energy Savings, decline in DTR failure rate and Carbon Savings • Annual Saving : INR 1.56 crore; Capital Cost: INR 1.76 crore; Payback period: 1 year 1 months |
| Gupta, Gill and Bansal (2012) | Effectiveness of High Voltage in Distribution System: High Voltage Distribution System | 11 kV feeder in Jammu and Kashmir | <ul style="list-style-type: none"> • Annual Saving : INR 86 lakh; Capital Cost: INR 1.95 crore; Payback period: 2.27 years |
| Bansal, Gill and Gupta (2012) | Minimization of Losses by Implementing High Voltage Distribution System in Agricultural Sector | BEHLLA feeder in Punjab | <ul style="list-style-type: none"> • Annual Saving : INR 0.75 lakh; Capital Cost: INR 2.25 lakh; Payback period: 3 years |
| Dembra and Sharma (2014 a) | High Voltage Distribution System For Agricultural Feeders In Distribution System | Agriculture Feeder in Madhya Pradesh | <ul style="list-style-type: none"> • Decline in power losses, copper losses, iron losses and transformer losses • Total losses per annum will decline from 12123 units to 8052 units |

| | | | |
|----------------------------|---|---------------------------------|---|
| Dembra and Sharma (2014 b) | Improvement in Voltage Profile and Loss Minimization Using High Voltage Distribution System | Agriculture Feeder in Punjab | <ul style="list-style-type: none"> • Decline in line losses from 13.76 % to 5.44 % • Increase in tail end voltage from 407V to 414V |
| Babu, Basani and B (2012) | HVDS approach for reducing the Technical and Non-technical losses to enhance the Electrical Distribution System performance | Hyderabad South Zone (Old City) | <ul style="list-style-type: none"> • Decline in technical losses from 15.1 % to 10.3 % • Non-technical losses will become zero in HVDS system |

The present study aims to conduct a detailed and comprehensive cost-benefit analysis including benefits for agricultural consumers in the state of Andhra Pradesh. The subsequent sections provides detailed description of assumptions, cost and benefits of the HVDS intervention considered in our analysis.

2.3 Data

2.3.1 Source of Data

Data on benefits and cost was sourced from secondary sources, mainly published papers and reports including journal papers, tariff orders, APDISCOMs business plans, cost schedule, Economic Survey (2018), All India Electricity Statistics, among others. The study has also carried out extensive literature search to derive estimates such as decline in pumpset failure rate and DTR failure rate.

2.3.2 Assumptions

The following sections provides detailed description of both general and specific assumptions along with respective data source.

General Assumptions:

Project Life

LT lines are proposed to be upgraded to HVDS in 2018 and the life of the project has been assumed to be 25 years i.e. till 2043. This is applicable for both the interventions, HVDS and EEPS.

Capex and Opex

All the costs are at 2017 price level and appropriate adjustments were made wherever required. Capex of HVDS system is based on ASCI report (2008), BESCO (2017) and UP Cost Schedule (2017) (**Table 6**). The operation and maintenance expenditure was assumed to be same as in counterfactual except for change in the transformer failure rate. For estimating the cost related to transformer failure, half are assumed to be replaced and balance repaired in both cases i.e. for existing LT as well as in case of HVDS. In case of repair, the cost of repair is assumed to be comprising of equal amount of capital and labour. The labour component has been escalated at real wage growth while the capital component is constant. The study has not ascribed any scrap value as the same is considered as equal to the cost of collecting and transporting the transformers.

Social Cost of Carbon

Estimates of carbon emissions avoided from fossil fuel fired plants have been sourced from a study by Tol (2014) and appropriate adjustment have been made in the social cost of carbon (**Table 5**).

Growth Rate of Pumpset

Pumpset data is sourced from All India Electricity Statistics (CEA, 2015).

Environmental and Social Cost and benefits

There are no further environmental and social cost due to HVDS intervention as explained in study by APEPDCL (2016).

The proposed HVDS intervention will ensure reliable electricity supply for agricultural purposes, potentially leading to increase in agricultural productivity and creating additional income opportunities. However, valuation of these benefits is out of the scope of this study as it focuses on issues related to power sector. Likewise, there may be potential gains in other sectors such as health, education and sanitation by utilizing Government monies released from subsidizing power sector losses and subsidies.

Table 5: General Assumptions

| Parameter | Data | Source |
|---|---------------------------|-----------------------------------|
| Capex Escalation | WPI of respective years | Ministry of Commerce and Industry |
| Project Life | 25 years | Assumption |
| Social Cost of Carbon at 5 % discount rate (2010 USD) | 7.6 USD/ tCO ₂ | (Tol, 2018) |

Specific Assumptions:

As discussed earlier, HVDS intervention in A.P. had already been started in 2006. Till 2017, network serving 8.97 lakh agricultural consumers out of 14.64 lakh was already covered under this system (APSPDCL, 2017; APEPDCL, 2017; CEA, 2015). Thus, for HVDS intervention, study has taken the remaining number of pumpset as the target. All the cost and benefits have been calculated on the basis of remaining network to be covered. In order to minimize losses and enhance individual accountability of DTR, the study has considered that individual HVDS transformer (16 kVA) will be provided to each pumpset. This will increase the sense of ownership and responsibility among the farmers and will result in decline in transformer failure due to overload.

As shown in **Figure 1**, AT&C losses were already low in A.P at approximately 12 per cent as 54 per cent network has already been upgraded to HVDS. Thus, the benefits in terms of energy savings have already been realized to a large extent. Also, there is a minimum level of line losses which cannot be eliminated due to law of physics. A review of evidence from implementation of HVDS schemes across various pilot sites revealed an average saving of 11 percent points, with a minimum of 8 percent points and maximum of 13 percent points (**Table 18 in Annexure-I**). Adopting a conservative approach, to account for the fact that benefits from pilots may be overstated due to peculiarities, this study adopted one-fourth of average savings i.e. 2.75 percentage points as base case energy savings from implementation of HVDS. A higher loss reduction will further improve BCR. The biggest uncertainty, particularly in HVDS intervention is the reduction in pumpset failure rate where the only evidence was from report by APEPDCL (2016). However, we have adopted a conservative approach by using one failure every year compared to 2-3 suggested by APEPDCL (2016) report. There will be some additional agricultural connections released every year. These have been not included for sake of

simplicity and because the BCR for those will be similar. Further, additional connections required in future are expected to be lower due to expansion of surface irrigation and consolidation of farms.

Table 6: Assumptions related to cost of HVDS Intervention

| Parameter | Data | Source |
|---|------------------------------------|---|
| Capex cost (Conversion of LT to HT Lines) | INR 29,623 | ASCI Report (2008) |
| Cost of HVDS transformer (16 kVA) | INR 70,717 | ASCI Report (2008) |
| Number of HVDS transformer required per pumpset | One 16 kVA transformer per pumpset | Assumption |
| Cost of repairing 100 kVA LT transformer | INR 21, 730 | BESCOM (2017) |
| Cost of replacing 100 kVA LT transformer | INR 1,25,057 | UP Cost Schedule (2017) |
| Cost of repairing 16 kVA HVDS transformer | INR 16,378 | Formula based |
| Labour cost | Escalated by real wage growth | CCC |

Table 7: Assumptions related to benefits from HVDS Intervention

| Parameter | Data | Source |
|---|--|---|
| Average Consumption per pumpset | 6,943 kWh | CEA (2015) |
| Reduction in AT&C losses due to HVDS | 2.75 % | Case Studies |
| Reduction trajectory of AT&C Losses YoY (Under BAU) | 0.3% (for reduction from 2018 to 2026) 0% (from 2027 onwards) | Projection based on historical evidence (Figure 1) |
| DTR failure rate (prior to HVDS) | 15 % | USAID |
| DTR failure rate (post HVDS) | 1 % | AP HVDS Ex-Ante Evaluation, JICA |
| Average cost of repairing a pumpset | INR 12,500 | APEPDCL (2016) |
| Frequency of Pumpset Failure | One per year | APEPDCL (2016) |

2.4 Calculation of Costs and Benefits

This section discusses the calculation of cost and benefits for HVDS intervention. To estimate the economic viability of the intervention, a standard cash flow analysis was used to calculate NPV and BCR of the interventions at 5 per cent discount rate.

2.4.1 Estimation of Costs

On the cost side, key items include capex of conversion of LT lines into HV (11 kV) lines and erection of HVDS transformer (16 kVA). To arrive at the total investment required, we have used the remaining number of agricultural pumpsets (7.8 lakh), assuming that each pump will require approximately 90 meters of lines based on historical average. We have used an individual transformer for each pump to enhance ownership, accountability and enable transparent estimation of savings. Total investment required for the intervention is the sum of these two and was estimated to be INR 7,147 crore at 5 per cent discount rate (**Table 8**).

2.4.2 Estimation of Benefits

There are four types of benefits resulting from HVDS intervention: energy savings, savings due to reduction in pumpset failure, savings due to reduction in DTR failure rate and carbon savings due to lower consumption. The value of energy savings was estimated based on the variable cost of power purchased from the marginal plant(s), based on APERC tariff order. The capital cost were not considered for three reasons. First, savings from HVDS decline over years as loss reduction (at a slower pace) was considered even under counterfactual based on historical trend. Hence, for A.P., savings from HVDS decline gradually and are nil by 2026. Second, the demand – supply scenario likely to prevail over medium term is expected to remain surplus given installed capacity of 330 GW and peak demand of about 165 GW. Further, the Government of India has expressed an ambition of adding 175 GW of renewable capacity. Third, the price of solar PV based power discovered in recent bidding were significantly lower (12%) than the variable cost of marginal plants considered in this analysis. Since pumpsets need to operate a 6-8 hours in a day, it is possible to consider a scenario where they were supplied entirely using solar power. Even otherwise, from economic standpoint, allocating full fixed cost to customer load requiring power for less than one third of time is not automatic and requires allocation based on marginal contribution to the peak demand. On the above basis, it was considered relevant and appropriate to use the marginal plant, but limit the savings potential on the basis of variable cost.

For valuing savings due to avoided DTR failure, we have assumed that 50 percent of the transformers which failed would have been replaced and remaining repaired. The transformers failure rate was 15 percent a year because of overloading, which is reduced considerably in case of HVDS to 1 percent. To calculate savings from reduction in pumpset failure, we have used a conservative approach of assuming that every pump fails once a year while the evidence from APEPDCL (2016) report indicates a higher rate i.e. 2-3 failure every year. Carbon savings were estimated using social cost of carbon. Total Benefits at 5 per cent discount rate were estimated to be INR 20,028 crore (**Table 8**).

The BCR for HVDS intervention at 5 per cent discount rate was 2.80 (**Table 8**). Therefore, we can conclude that the intervention to upgrade existing LT network to HVDS was economically viable.

Table 8: Cost and Benefits of HVDS intervention

| Costs | INR Crore | Benefits | INR Crore |
|-------------------|--------------|---|---------------|
| Capex | 7,147 | Value of Energy Savings | 232 |
| | | Value of Carbon Saving | 45 |
| | | Savings (Reduction in pumpset failure) | 18,944 |
| | | Savings (Reduction in DTR failure rate) | 807 |
| Total Cost | 7,147 | Total Benefit | 20,028 |

Source: Author's Calculation; Notes: All figures assume a 5% discount rate

2.5 Assessment of Quality of Evidence

The quality of evidence was 'Moderate/Strong' for both interventions. Study has sourced majority of data from published reports. However, limited evidence exists for some of the variables such as DTR failure rate, pumpset failure rate, etc. The biggest uncertainty is the pumpset failure rate where the evidence only was reported by (APEPDCL 2016). However, we have adopted a conservative approach by using one failure every year compared to 2-3 suggested by (APEPDCL 2016) report. Further, sensitivity analysis was performed on key variables to evaluate the impact of uncertainty.

2.6 Sensitivity Analysis

Several variables were tested for sensitivity including reduction in AT&C losses, additional fixed cost of power purchase, capex for HVDS, frequency of pumpset failure in a year, average cost of repairing pumpset and DTR failure rate prior to implementation of HVDS. However, BCR was most sensitive to only three key risk factors. The key variables along with the considered range are discussed in **Table 9**.

Table 9: Variables and range for Sensitivity Analysis

| Risk Factors | Case I | Case II |
|--|--------|---------|
| Increase in capital investment cost for HVDS | 10% | 30% |
| Frequency of pumpset failure in a year | 0.5 | 2 |
| Average cost of repairing pumpset | 25% | 50% |

Table 10 represents the results of sensitivities for variables having a significant impact on the BCR. These include variables with relatively higher uncertainty regarding the base case value.

Table 10: Results of Sensitivities under HVDS intervention

| Sensitivity | Base Case | Case I | Case II |
|--|-----------|--------|---------|
| Capex for HVDS | 2.80 | 2.55 | 2.16 |
| Frequency of pumpset failure in a year | 2.80 | 1.48 | 5.45 |
| Average cost of repairing a pumpset | 2.80 | 3.46 | 4.13 |

Source: Author's Calculations; Notes: All figures assume a 5% discount rate

As the majority of benefits in the first intervention are in terms of savings from reduction in pumpset failure, varying frequency of pumpset failure had major impact on BCR. Changing the frequency of pumpset failure from 1 to 0.5 and 1 to 2 results in large variation in BCR from 2.80 to 1.48 and 2.80 to 5.45 respectively at 5 per cent discount rate. However, HVDS intervention remains economically viable in all scenarios.

3. HVDS and Energy Efficient Agricultural Pumpsets (EEPS)

3.1 Description of intervention

The agriculture sector is one of the major inefficient user of power in India due to unmetered supply and zero marginal tariff. Hence, it provides significant opportunity to reduce AT&C losses and save energy through better demand side management strategies. The water use efficiency in India at about 30-40 percent, one of the lowest in the world (EESL, 2014).

The irrigation pumpsets used are generally in India inefficient with operating efficiency level of 30% or less. The pumpsets are generally oversized to extract water from increasingly lower ground water levels and also to withstand large voltage fluctuations. The energy consumption is high mainly due to improper selection and installation, use of high-friction piping, lack of proper maintenance and frequent repairs. Demand for water for agriculture is expected to increase from 470 Billion Cubic Metres (BCM) in 1985 to 740 BCM in 2025 (EESL, 2014). However, the actual availability of the water will reduce from 83% to 69%, resulting in increasing stress on water availability and thereby on farmers (EESL, 2014). Such a scenario will likely further increase energy intensity of pumping due to lowering of water table.

Across the states, share of agriculture sector in total sales of electricity has been one of the highest in Andhra Pradesh. APDISCOMs have proposed to replace 1lakh inefficient pumps with energy efficient pumps on pilot basis (APEPDCL, 2017; APSPDCL, 2017). In this intervention, the study has proposed to replace the existing inefficient pumpsets (1.5 million) of 7 HP capacity (on an average) with BEE five rated 5 HP capacity (on an average) pumpsets with free service and maintenance for a period of five years. Old pumpsets will be destroyed so that they do not enter back into farms through grey market channels. The present study evaluates the cost and benefit of energy efficient pumpsets with HVDS as a pre-requisite. This is so because improving quality of supply is critical to ensure that the new EEPS will not burn out same as old pumpsets or consume more than designed energy.

3.2 Literature Review

Power distribution system in India is characterized with AT&C losses significantly higher than the international norm of 15 per cent (Kapure and Mahajan, 2016). Poor operational

performance and financial losses has resulted in sub-optimal investments in network upgrades. Agricultural consumers i.e. farmers bear the brunt of the situation since they are at the tail end of the network and hence exposed to maximum number of interruptions, lowest possible voltage and customer service. It is hence not surprising that they have developed mitigating strategies including buying robust but highly inefficient pumpset, political patronage to continue tariff subsidies which distort consumption and investment patterns in many parts of the economy. Given the situation, this situation presents a significant opportunity. For example, evidence from pilot projects demonstrates that energy intensity of pumping can be reduced by 20 percent to 50 per cent by relatively easy methods such as replacing the inefficient pumpset with more efficient ones. Several pilot projects have been carried out to examine the improvement in end use efficiency in agriculture sector by replacement of existing pumpsets and accessories. From the experiences of pilots in BESCO, it has been noted that there exists overall energy saving potential of around 35 to 65 per cent by replacement of existing inefficient pumpsets and accessories (Ag-DSM, 2011).

Crossely (2008) studied Agricultural Pumpset Efficiency Improvement Program developed by the Noida Power Company Limited (NPCL) and implemented jointly with manufacturers of energy efficient pumps and other equipment, and by financial institutions. The NPCL distribution system servicing the agricultural sector was characterized by high line losses, wastage of energy in running pumpsets (7500 kWh per agricultural consumer per annum), low revenue generation and high levels of theft and pilferage of electricity. It was observed that replacement of a conventional 7 HP pumpset with a high efficiency 3HP pumpset resulted in decline in energy consumption (67 per cent) from 10,800 kWh to 3,510 kWh per year and increased power factor from 0.65 to 0.85.

Desai and Aiholli (2017) evaluated operating efficiency of 1,337 agricultural pumpsets in the Mandya District, Karnataka. They identified various factors that could affect the pump performance such as inferior design, improper pump selection and usage, undersized pipes, suction head variations and large discharge length and motor rewinding and low voltage profile. They estimated the energy saving potential due to replacement of existing pumpsets with energy efficient pumpsets. They observed that weighted average operating efficiency of all the existing pumpsets was 28.3 per cent and the efficiency of the new proposed pumps was

51 per cent (submersible) and 55 per cent (monoblock). The achievable energy savings were estimated to be 44 per cent and in terms of quantum, the overall consumption by pumpsets could be reduced from 10 Million Units (MU) to 6 MU, i.e. reduction of 40 per cent.

EESL (2014) studied the case of 317 agricultural pumpsets in the East Godvari District of Andhra Pradesh. They observed that major reasons for pumpset failure and lower discharge output was erratic power supply and variation in water levels leading to incorrect selection with respect to head. As a result, power consumption of the pumpsets was more than the sanctioned load. The overall average operating efficiency of old pumpsets was around 25 per cent with an average energy consumption of 18.64 kW. In case of energy efficient pumpsets, overall operating efficiency was 34 per cent.

International Energy Initiative and Prayas (2010) has studied several energy efficiency initiatives related to agriculture implemented in the states of Gujarat, Tamil Nadu, Andhra Pradesh, Maharashtra and Punjab. In case of Gujarat, in 1997-98, existing pumps were replaced by a mono-block pump of lower capacity, but providing at least equivalent discharge. This resulted in energy saving of 24 per cent to 69 per cent. In case of Tamil Nadu, energy saving due to rectification of suction and delivery pipes alone were between 8– 14 per cent, out of overall saving of 19 per cent (**Table 11**).

Our review suggests that only the Water-Energy Nexus (WENEXA) program in Karnataka under USAID funding (Ag-DSM, 2011) implemented the EEPS with HVDS under Ag-DSM. Under this project, total number of 277 pumpsets were replaced by high EEPS in Doddballapura Sub-Division. As a result, BESCO has saved 29.23 MU from April 2011 to June 2013 at Doddaballapura (BESCO, 2013). As efficient pumpsets are equally likely to fail in the absence of HVDS, the savings from replacing inefficient pumpset with efficient ones are unlikely to be sustained in the absence of HVDS. Hence, the study strongly believes that EEPS needs to be implemented with HVDS and metering as precondition. Such an effort will likely require farmer awareness due to perceived reluctance to metering. However, such a strategy has a significantly higher probability of sustained savings as demonstrated by experience of the WENEXA program implemented in Karnataka.

Table 11: Summary of Findings from different studies focusing on EEPS

| Author | Objective | Study Areas | Findings |
|---|--|--|--|
| Crossely (2008) | Agricultural Pumpset Efficiency Improvement Program – India | Noida | <ul style="list-style-type: none"> • Replacement of a conventional 7 HP pumpset with a high efficiency 3 HP pumpset. • Decline in energy consumption from 10,800 kWh to 3,510 kWh per year • Increase in power factor from 0.65 to 0.85 |
| Desai and Aiholli (2017) | Agricultural Demand Side Management: A Case Study of Mandya District, Karnataka, India. | Mandya District, Karnataka | <ul style="list-style-type: none"> • Achievable energy savings is estimated at 44 %. • Decline in overall consumption by pumpsets from 10.07 MU to 5.63 MU |
| EESL (2014) | Pilot Ag-DSM Project at Rajanagaram Mandal In East Godavari District, Andhra Pradesh | East Godavari District, Andhra Pradesh | <ul style="list-style-type: none"> • Average operating efficiency was around 25 % with an average energy consumption of 18.64 kW • Power consumption of the pumpsets is more than the sanctioned load |
| International Energy Initiative and Prayas (2010) | Efficient well-based irrigation in India: Compilation of experiences with implementing irrigation efficiency | All India Case Study | <ul style="list-style-type: none"> • Gujarat energy saving range from 24 to 69 % due to replacement of old pumpset with EEPS • In Tamil Nadu energy saving by rectification of suction and delivery pipes alone was 8 to 14 % |

3.3 Data

All the general and specific assumptions presented in **section 2.3** are same for this intervention as well. According to CEA (2015), average pumpset size in case of A.P. is approximately 7 HP. Considering average pumpset size in A.P. and 30 per cent energy saving as suggested by APSPDCL petition (2017), study has considered the case where all the existing pumpsets are proposed to be replaced with 5HP (5 star rated) EEPS in 2018. The cost for pumpsets and installation were sourced from APSPDCL petition (2017) (**Table 12**). Meter cost were sourced from ASCI Report (2008). As explained previously, new connections were not considered for sake of simplicity and because the benefits will be similar. As per the EESL (2014) report, energy savings from EEPS were as high as 50 per cent. However, we have adopted a conservative

estimate of energy savings as 30 per cent (**Table 13**). Further, old pumpsets will be taken back by the implementing agency and destroyed to ensure that they are not recycled back through the grey market. The study has not ascribed any scrap value as the same is considered as equal to the cost of collecting, transporting and destroying the pumpsets.

Table 12: Assumptions related to cost of HVDS and EEPS Intervention

| Parameter | Data | Source |
|-------------------|-------------|------------------|
| EEPS (5HP) | INR 37, 676 | APSPDCL Petition |
| Installation cost | INR 4,600 | APSPDCL Petition |
| Meter cost | INR 1,970 | ASCI Report |

Table 13: Assumptions related to benefits from HVDS and EEPS Intervention

| Parameter | Data | Source |
|----------------------------|------|------------------|
| Energy Savings due to EEPS | 30% | APEPDCL Petition |

3.4 Calculation of Costs and Benefits

This section discusses the calculation of cost and benefits for EEPS intervention. To study the economic viability of the intervention and to calculate NPV and BCR of interventions at 5 per cent discount rate.

3.4.1 Estimation of Costs

On the cost side, key items include capex of conversion of LT lines into HVDS, capex cost of erection of HVDS transformer (16 kVA), cost of EEPS (5HP), installation cost and meter cost. Calculation related to HVDS intervention remains same. To arrive at the total investment required, we have used the total number of energized pumpsets assuming that each pumpset will require one meter. There were 15.7 lakh pumpsets in 2015 in A.P (CEA, 2015). The number of pumpsets has been appropriately adjusted to derive the number of pumpsets in 2017. Total capital investment required for the intervention is the sum of these two and were estimated to be INR 14,164 crore at 5 per cent discount rate (**Table 14**).

3.4.2 Estimation of Benefits

There are four types of benefits resulting from HVDS and EEPS intervention: energy savings, savings due to reduction in pumpset failure, savings due to reduction in DTR failure rate and carbon savings. All the calculation remains same in this case except energy savings and carbon savings. The value the energy saving was estimated based on the variable cost of power purchase from marginal plant, based on RERC tariff order. As explained under intervention 1, fixed cost of power purchase were not included. In this intervention, both energy and carbon savings will be higher as new pumpsets require 30 per cent less energy. Total benefits was estimated to be INR 43,294 crore at 5 per cent discount rate (**Table 14**).

The BCR for HVDS intervention at 5 per cent discount rate is 3.06 (**Table 14**). Therefore, we can conclude that the intervention to replace inefficient pumpsets with EEPS is economically viable.

Table 14: Cost and Benefits of HVDS and EEPS intervention

| Costs | INR Crore | Benefits | INR Crore |
|-------------------|---------------|---|---------------|
| Capex | 14,164 | Value of Energy Savings | 17,819 |
| | | Value of Carbon Saving | 5,724 |
| | | Savings (Reduction in pumpset failure) | 18,944 |
| | | Savings (Reduction in DTR failure rate) | 807 |
| Total Cost | 14,164 | Total Benefit | 43,294 |

Source: Author's Calculation; Notes: All figures assume a 5% discount rate

3.5 Sensitivity Analysis

Several variables were tested for sensitivity including capex cost for EEPS, energy savings due to EEPS, including capital (fixed) component of power purchase, frequency of pumpset failure in a year and average cost of repairing pumpset. However, BCR was most sensitive to only three key risk factors (as shown in **Table 15**). The study has used average pumpset size of 5HP for EEPS. However, ground water depth varies in the state from (-) 0.09 m below ground level (bgl) in West Godavari district to 24 m bgl in Prakasham district in 2014-15 (CGWB, 2016). Thus, to

overcome this limitation, we have also performed the sensitivity by using cost of 7.5 HP pumpsets instead of 5HP.

Table 15: Key risk factors for Sensitivity Analysis

| Risk Factors | Case I | Case II |
|--|-------------|-------------|
| Energy savings due to EEPS | 20% | 40% |
| Frequency of pumpset failure in a year | 0.5 | 2 |
| Average cost of repairing pumpset | 25% | 50% |
| Cost of 7.5 HP pump instead of 5 HP | INR 43,850 | |
| Fixed cost of power purchase (levelized) | INR 1.0/kWh | INR 1.5/kWh |

Table 16 represents results of sensitivities where change in the variable results in a significant impact on the BCR. These include variables with relatively higher uncertainty regarding the base case value.

Table 16: Results of Sensitivities under HVDS and EEPS intervention

| Sensitivity | Base Case | Case I | Case II |
|--|-----------|--------|---------|
| Frequency of pumpset failure in a year | 3.06 | 2.29 | 4.39 |
| Average cost of repairing pumpset | 3.06 | 3.39 | 3.73 |
| Energy saving due to EEPS | 3.06 | 2.52 | 3.60 |
| Cost of 7.5 HP pump instead of 5 HP | 3.06 | 2.87 | |
| Fixed cost of power purchase (levelized) | 3.06 | 3.46 | 3.66 |

Source: Author's Calculation; Notes: All figures assume a 5% discount rate

The result of the sensitivities are shown in (**Table 16**). The results are similar to previous intervention with cost of pumpset repair and frequency of pumpset failure as the key risk factors. Changing the frequency of pumpset failure from 1 to 0.5 and 1 to 2 results in large variation in BCR from 3.06 to 2.29 and 3.06 to 4.39 respectively at 5 per cent discount rate. In this case, if energy savings due to EEPS increase to 40 per cent, BCR increases from 3.06 to 3.60. There is a decline in BCR from 3.06 to 2.87 if 7.5 HP pumpset is used instead of 5HP pumpset. However, for all the sensitivities, the project remain financially viable. Also, if we

include fixed cost of INR 1.0/kWh (levelized) and INR 1.5/kWh to power purchase, BCR increases from 3.06 to 3.46 and 3.06 to 3.66 respectively. However, for all the sensitivities, the project remain economically viable.

4. Conclusion

In India, power distribution system has been characterized with high distribution losses. Agriculture sector is one of the major and inefficient user of power and provides immense opportunity to reduce these losses and save energy through better demand side management techniques. It comprises of usage of inefficient pumpsets, subsidized electricity, and over-exploitation of ground water. As a result, farmers deploy low cost inefficient pumpsets for irrigation as a mitigating strategy to erratic and poor quality supply. Unmetered supply, zero marginal cost and state subsidies have locked the segment into a vicious cycle of declining water availability, increasing energy intensity and stress on state finances.

To address these challenges, strategic interventions are required to break the vicious cycle. The study believes that two most relevant strategies are up-gradation of LT network to HVDS and replacement of inefficient pumpsets with EEPS. This paper has carried out cost-benefit analysis of these two interventions for A.P. HVDS and EEPS interventions offer several benefits such as reduction in AT&C losses, improved quality of supply, reduction in pumpset failure, and decline in DTR failure rate, among others. They also result in environmental benefits in terms of avoided carbon emissions as majority of the power plants in India are coal based. Due to HVDS and usage of EEPS, system efficiency will be increased resulting in significantly lower energy consumption. The paper found out that both the interventions were economically viable but benefits were higher in the second case i.e. EEPS and HVDS (**Table 17**).

In A.P., 54 per cent of network serving agricultural consumers had already been converted into HVDS. In case of EEPS, APDISCOMs has proposed to replace 1 lakh inefficient pumps with energy efficient pumps on pilot basis (APEPDCL, 2017; APSPDCL, 2017). Due to substantial penetration of HVDS in A.P., benefits in case of HVDS intervention were less compared to combined second intervention. Another factor contributing to additional benefits in second intervention is the rural-urban mix of A.P. as more than 70 per cent population is rural. As efficient pumpsets are equally likely to fail in the absence of HVDS, the savings from replacing

inefficient pumpset with efficient ones are unlikely to be sustained in the absence of HVDS. Thus, it makes case for carrying out both the interventions simultaneously.

Table 17: Summary of Benefits, Cost and BCR at three discount rate

| Interventions | Discount | Benefit (INR Crore) | Cost (INR Crore) | BCR | Quality of Evidence |
|---------------|----------|---------------------|------------------|------|---------------------|
| HVDS | 3% | ₹ 25,462 | ₹ 7,286 | 3.49 | Strong/Moderate |
| | 5% | ₹ 20,028 | ₹ 7,147 | 2.80 | |
| | 8% | ₹ 14,658 | ₹ 6,949 | 2.11 | |
| HVDS and EEPS | 3% | ₹ 66,200 | ₹ 14,439 | 4.58 | Strong/Moderate |
| | 5% | ₹ 43,294 | ₹ 14,164 | 3.06 | |
| | 8% | ₹ 27,916 | ₹ 13,770 | 2.03 | |

Source: Author's Calculation

The study believes that state wide implementation of these two interventions offers a significant opportunity for the power sector, particularly DISCOMs but equally importantly for their owners i.e. the State Government. Given the large benefit from the interventions, particularly EEPS along with HVDS, we recommend that pilot projects should be initiated at the earliest, starting from sites with highest losses and maximum number of agricultural connections. We are also of the opinion that given the relatively large capex requirements and dispersed nature of the agricultural consumers, it will be relevant to involve other stakeholders such as private sector, farmers' co-ops, NGOs and state administrative machinery to ensure its success.

5. References

1. Ag-DSM. (2011). A Guide Book To Implement Agriculture Demand Side Management On Water And Energy Side.
2. Alam, M., Gain, M., Yasin, S. M. and Mondal, S. (2014). Distribution Sector Reform in India: An overview. *International Journal of Engineering Research and Development*, 10(10), pp: 69-79.
3. APERC. (2015). Retail Supply Tariffs 2016-17. Hyderabad: Andhra Pradesh Electricity Regulatory Commission (APERC).
4. APERC. (2016). Retail Supply Tariffs 2016-17. Hyderabad: Andhra Pradesh Electricity Regulatory Commission (APERC).
5. APERC. (2017). Retail Supply Tariffs 2016-17. Hyderabad: Andhra Pradesh Electricity Regulatory Commission (APERC).
6. APERC. (2018). Retail Supply Tariffs 2018-19. Hyderabad: Andhra Pradesh Electricity Regulatory Commission (APERC).
7. APEPDCL. (2017). *Business Plan*. Vishakhapatnam, Andhra Pradesh: Eastern Power Distribution Company of A.P Limited (APEPDCL). Retrieved from:
https://www.apeasternpower.com/ShowProperty/EP_CM_REPO/Whats%20New/Business%20Plan%20of%20APEPDCL
8. APSPDCL Petition Order. (2017). Retrieved from:
http://www.aperc.gov.in/aperc1/assets/uploads/files/73bdc-sp_pumpsets.pdf
9. APSPDCL. (2016). *Environmental and Social Management Plan for Rural HVDS Project*. Tirupati, Andhra Pradesh: Southern Power Distribution Company of A.P Limited (APSPDCL). Retrieved from:
https://www.apeasternpower.com/ShowProperty/EP_CM_REPO/Pages/Home/RIGHT%20LINKS/Generic%20Environmental
10. APSPDCL. (2017). *Business Plan*. Tirupati, Andhra Pradesh: Southern Power Distribution Company of A.P Limited (APSPDCL). Retrieved from:
<http://www.aperc.gov.in/aperc1/assets/uploads/files/58cc4-apspdcl.pdf>
11. ASCI report (2008). *Study on Capital Costs Benchmarks for Distribution Business*. Hyderabad: Administrative Staff College of India (ASCI). Retrieved from:
<http://npti.in/Download/Distribution/Capital%20Cost%20Benchmarks%20for%20Distribution%20Business%20-%20Administrative%20Staff%20College%20of%20India.pdf>
12. Bansal, I., Gill, H.S. & Gupta, A. (2012). Minimization of Losses by Implementing High Voltage Distribution System in Agricultural Sector. *IOSR Journal of Electrical and Electronics Engineering*, 1(5), pp: 39-45.

13. BESCO. (2013). Demand Side Management: PPT. Retrieved from: bescom.org/wp-content/uploads/2014/.../DSM-Activities-as-on-November-2014-1.ppt.
14. BESCO. (2017). *Item wise repair charges for transformer and Testing and Pre commissioning charges*. Bangalore: Bangalore Electricity Supply Company Limited (BESCO).
15. CEA. (2014). *All India Electricity Statistics: Annual Reports*. Delhi: Central Electricity Authority (CEA).
16. CEA. (2015). *All India Electricity Statistics: Annual Reports*. Delhi: Central Electricity Authority (CEA).
17. Crossley, D. (2008). Agricultural Pump Set Efficiency Improvement Program – India.
18. CWGB. (2016). *Ground Water Year Book 2014-15 Andhra Pradesh*. Hyderabad: Ministry of Water Resource. Retrieved from: <http://cgwb.gov.in/Regions/GW-year-Books/GWYB-2014-15/GWYB%2014-15%20Andhra%20Pradesh.pdf>
19. Dembra, A. & Sharma, A.K. (2014 a). High Voltage Distribution System For Agricultural Feeders In Distribution System. *International Journal of Engineering Research and Reviews*, 2(3), pp: 1-8.
20. Dembra, A. & Sharma, A.K. (2014 b). Improvement in Voltage Profile and Loss Minimization Using High Voltage Distribution System. *International Journal of Electrical and Electronics Research*, 2(3), pp: 11-20.
21. DERC. (2017). Tariffs Order 2017-18. New Delhi: Delhi Electricity Regulatory Commission (DERC).
22. Desai, A. A. & Aiholli, N. (2017). Agricultural Demand Side Management: A Case Study of Mandya District, Karnataka, India. *International Journal of Innovations in Engineering and Technology*, 8(1), pp: 15- 24.
23. Economic Survey. (2018). Delhi: Ministry of Finance, Government of India. Retrieved from: <http://mofapp.nic.in:8080/economicsurvey/>
24. EESL. (2014). *Pilot AgDSM Project at Rajanagaram Mandal In East Godavari District, Andhra Pradesh: Detailed Project Report*. Andhra Pradesh: Energy Efficiency Services Limited (EESL). Retrieved from: [https://www.apeasternpower.com/ShowProperty/EP_CM_REPO/Pages/Home/APERC%20Related%20\(Tariff,%20FSA.\)/RevaildDPR%20byEESLatRajanagaram](https://www.apeasternpower.com/ShowProperty/EP_CM_REPO/Pages/Home/APERC%20Related%20(Tariff,%20FSA.)/RevaildDPR%20byEESLatRajanagaram)
25. FICCI. (2017). *Agricultural Demand Side Management (Ag-DSM) Program in India: Adopting Technologies to Boost Efficiencies*. New Delhi: Federation of Indian Chamber of Commerce and Industry (FICCI). Retrieved from: <http://ficci.in/spdocument/20804/White-Paper-AgDSM-Workshop.pdf>
26. Gandhi.V.B. (2017). *Presentation on AT&C losses*. Gujarat: Gujarat Urja Vikas Nigam Ltd (GUVNL).

27. GoI & GoAP. (2017). *Power for All*. Andhra Pradesh: Government of Andhra Pradesh (GoAP).
Retrieved from:
https://powermin.nic.in/sites/default/files/uploads/joint_initiative_of_govt_of_india_and_andhra_pradesh_0.pdf
28. Gupta, A., Gill, H.S., & Bansal, I. (2012). Effectiveness of High Voltage in Distribution System: High Voltage Distribution System. *IOSR Journal of Electrical and Electronics Engineering*, 1(5), pp: 34-38.
29. Indian Power Sector Report. (2013). *Power Plus Distribution*. Retrieved from:
<http://indianpowersector.com/home/wp-content/uploads/2013/03/power-plus-Distribution-new.pdf>
30. International Energy Initiative & Prayas (2010). *Efficient well-based irrigation in India: Compilation of experiences with implementing irrigation efficiency*. Bangalore: International Energy Initiative.
31. Jahnvi, W.V. (2014). Reduction of Losses in Distribution System Using HVDS with Real Time Application. *International Journal of Advanced Research in Electrical, Electronics and Instrumentation Engineering*, 3(9), pp: 11960-11969.
32. Kapure, V. & Mahajan, K.M. (2016). Review on loss reduction by improving ratio of HT/LT line in Electrical Distribution System. *International Journal of Engineering Research and General Science*, 4(1), pp: 155-163.
33. MOSPI. URL: <http://www.mospi.gov.in/>
34. PFC. (2016). *Report on the Performance of State Power Utilities*. New Delhi: Power Finance Corporation (PFC).
35. PFC. (2017). *Report on the Performance of State Power Utilities*. New Delhi: Power Finance Corporation (PFC).
36. RBI (Reserve Bank of India). URL: <https://www.rbi.org.in/scripts/referenceratearchive.aspx>
37. Reddy, V. N., Rao, S. K. & Kumar, S. K. (2016). Comparative Study on Loss & Cost Minimization by Using High Voltage Distribution System. *Imperial Journal of Interdisciplinary Research*, 2(11), pp: 1657-1661.
38. Sharma, N. & Mittal, A. (2016). Techno-Economic Analysis for Electrical Energy Saving in Distribution Sector. *International Journal of Advanced Research in Electrical, Electronics and Instrumentation Engineering*, 5(6), pp: 5064-5072.
39. Tol, R., 2018. The Economic Impacts of Climate Change. *Review of Environmental Economics and Policy*, 12(1), p. 4–25.
40. UP Cost Schedule. (2017). *Cost Schedule*. Uttar Pradesh: Uttar Pradesh Power Corporation Limited (UPPCL). Retrieved from:

<https://www.dvvn1.org/UploadFiles/CurrentNews/UPPCL%20Resspo%20Cost%20Schedule%202017-18.pdf>

41. USAID. (2010). *Best Practices in Technical Loss Reduction –Case Studies*. Retrieved from:
https://sari-energy.org/oldsite/PageFiles/What_We_Do/activities/Afghan_Capacity_Building_Program_Aug_09/distribution_loss_program_july-aug_2010/presentations/English/4Case_Studies_in_Technical_Loss_Reduction.pdf
42. World Bank. URL: <http://databank.worldbank.org/data/databases/commodity-price-data>

6. Annexure

Table 18 : Case studies of Energy Savings

| State | District | Rural/ Urban | Area/ Feeder | LT (AT&C losses) | HVDS (AT&C losses) | Energy Savings |
|-------------------------------|----------|-----------------|----------------------|---------------------|-----------------------|-------------------|
| A.P. | Chittor | Rural | Bangarpalem –SS | 16% | 3.8% | 13% |
| A.P. | Krishna | Rural | Patnam-SS | 17% | 5.3% | 12% |
| A.P. | Bellary | Rural | Kotturu-S1 | 19% | 5.5% | 13% |
| A.P. | Chittor | Rural | Murakambattu- SS2 | 14% | 5.4% | 8% |
| Average Energy Savings | | | | | | 11% |

Consensus was conceived to address a fundamental, but overlooked topic in international development: In a world with limited budgets and attention spans, we need to find effective ways to do the most good for the most people. The Copenhagen Consensus works with 300+ of the world's top economists including 7 Nobel Laureates to prioritize solutions to the world's biggest problems, on the basis of data and cost-benefit analysis.

As a new state, Andhra Pradesh faces a bright future, but it is still experiencing many acute social and economic development challenges. It has made great strides in creating a positive environment for business, and was recently ranked 2nd in India for ease of doing business. Yet, progress needs to be much faster if it is to achieve its ambitions of becoming the leading state in India in terms of social development and economic growth. With limited resources and time, it is crucial that focus is informed by what will do the most good for each rupee spent. The Andhra Pradesh Priorities project as part of the larger India Consensus – a partnership between Tata Trusts and the Copenhagen Consensus Center, will work with stakeholders across the state to identify, analyze, rank and disseminate the best solutions for the state. We will engage people and institutions from all parts of society, through newspapers, radio and TV, along with NGOs, decision makers, sector experts and businesses to propose the most relevant solutions to these challenges. We will commission some of the best economists in India, Andhra Pradesh, and the world to calculate the social, environmental and economic costs and benefits of these proposals



ANDHRA PRADESH PRIORITIES

AN
INDIA CONSENSUS
PRIORITIZATION
PROJECT

For more information visit www.APpriorities.com

C O P E N H A G E N C O N S E N S U S C E N T E R

Copenhagen Consensus Center is a think tank that investigates and publishes the best policies and investment opportunities based on social good (measured in dollars, but also incorporating e.g. welfare, health and environmental protection) for every dollar spent. The Copenhagen Consensus was conceived to address a fundamental, but overlooked topic in international development: In a world with limited budgets and attention spans, we need to find effective ways to do the most good for the most people. The Copenhagen Consensus works with 300+ of the world's top economists including 7 Nobel Laureates to prioritize solutions to the world's biggest problems, on the basis of data and cost-benefit analysis.